

Model code : DET_11MA016ST006
Print date: 02/02/2016
Last updated: 02/02/2016

Prepared for :

T 430.18 4X2 T E6 - GVW 18T / GCW 44.00 T

RENAULT TRUCKS

T 430

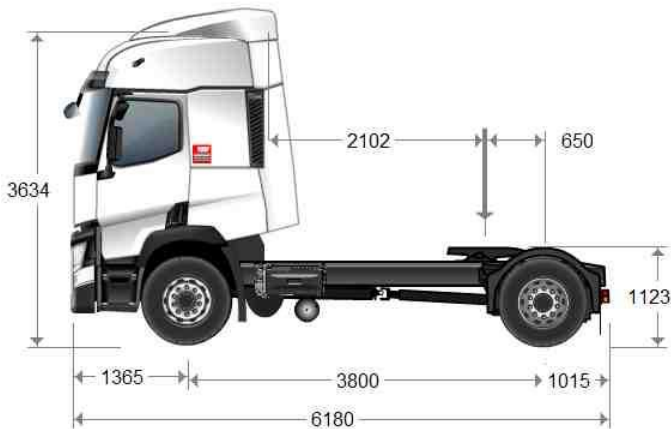

WEIGHTS

Wheelbase		mm	3.800
Maximum Weight (registered)	Total (GVW)	Kg	18000
Payload	(C)	Kg	9737
Maximum Weight (registered)	Front axle 1	Kg	7500.00
	rear axle 1	Kg	11500
Min. weight complete vehicle unladen	Front axle(s)	Kg	5974.00
Kerb Weight	total	Kg	8263
Chassis cab kerb weight	Front Axle 1	Kg	5501.00
	Rear Axle 1	Kg	2762.00
Total vehicle weight under full load at YMIN	Front axle(s)	Kg	
	Rear axle(s)	Kg	
Total vehicle weight under full load at YMAX	Front axle(s)	Kg	
	Rear axle(s)	Kg	

To maintain the driving comfort (lightness of steering, braking) of vehicles in all load and driving conditions once the vehicle is bodied, the following minimum axle load(s) must be respected: A value corresponding to 29% of the weight of the unladen bodied vehicle kerb weight (with driver, without passenger)

This table includes the weights of the RENAULT TRUCKS options: full urea tank, oil, screen wash fluid and coolant at 100%, fuel fill level 90% and driver present (75kg).



LENGTHS

Wheelbase		mm	3.800
Front Overhang	(H / BEP L016)	mm	1365
Wheelbase	(F / BEP L011)	mm	3800
Rear overhang	Chassis	mm	1015
Centre of Gravity of vehicle	at X (BEP L044)	mm	1282.00
Overall Chassis Length	(A / BEP L032+L016)	mm	6180

HEIGHTS

Wheelbase		mm	3.800
Ground clearance, laden	Front (U1 / BEP H015)	mm	231
	Rear (U3 / BEP H016)	mm	212
Max. exterior height unladen	(BEP H001)	mm	3918
Max. exterior height, cab tilted, unladen	(O1 / BEP H061)	mm	4382.00
Cab height (unladen)	(O)	mm	3634
Distance from ground to lowest point at front of vehicle	Unladen (H0 / BEP H18)	mm	349.00
	Laden (H0 / BEP H18)	mm	287.00
Frame top height at front axle	Unladen (H1 / BEP H035)	mm	973.00
	Laden (H1 / BEP H036)	mm	922.00
Frame top height at drive axle	Unladen (H2 / BEP H037)	mm	954
	Laden (H2 / BEP H038)	mm	931
Frame top height at the rear of the frame	Unladen (HN)	mm	949.00
	Laden (HN)	mm	934.00
Centre of Gravity of vehicle	Unladen at Z (BEP H044)	mm	920.00
Side member height	(BEP H032)	mm	266.00

TOWING DEVICE

Wheelbase		mm	3.800
Distance between the front of the vehicle and the centre of the trailer coupling device	(BEP L073 + L016)	mm	4515.00
Distance between centre of last axle to centre of coupling device		mm	
Fifth wheel height, from top of side member	(BEP H074 + H071)	mm	166.00
Fifth wheel height from ground	Unladen (BEP H076)	mm	1123
	Laden (BEP H078)	mm	1096
Swept Swing Clearance	(BEP L078)	mm	2102.00
Fifth wheel position	Max. (Ymax / BEP L075)	mm	850
Gross Vehicle Weight	at YMAX	Kg	18000.00
Gross Vehicle Weight, load on front axle(s)	at YMAX	Kg	7500.00
Gross Vehicle Weight, load on rear axle(s)	at YMAX	Kg	10500.00
King Pin Load	at YMAX	Kg	9737.00
King Pin Load on Front Axle(s)	at YMAX	Kg	1999.00
King Pin Load on RearAxle(s)	at YMAX	Kg	7738.00
Fifth wheel position	Min. (Ymin / BEP L077)	mm	150
Gross Vehicle Weight	at YMIN	Kg	18000.00
Gross Vehicle Weight, load on front axle(s)	at YMIN	Kg	6500.00
Gross Vehicle Weight, load on rear axle(s)	at YMIN	Kg	11500.00
King Pin Load	at YMIN	Kg	9737.00
King Pin Load on Front Axle(s)	at YMIN	Kg	999.00
King Pin Load on RearAxle(s)	at YMIN	Kg	8738.00
Fifth wheel position	Manufacturer's recommendation (Y / BEP L076)	mm	650
Gross Vehicle Weight	in fifth wheel position recommended by manufacturer	Kg	18000.00
Gross Vehicle Weight, load on front axle(s)	in fifth wheel position recommended by manufacturer	Kg	7167.00
Gross Vehicle Weight, load on rear axle(s)	in fifth wheel position recommended by manufacturer	Kg	10833.00

King Pin Load	in fifth wheel position recommended by manufacturer	Kg	9737.00
King Pin Load on Front Axle(s)	in fifth wheel position recommended by manufacturer	Kg	1666.00
King Pin Load on RearAxle(s)	in fifth wheel position recommended by manufacturer	Kg	8071.00
Fifth wheel position	Intermediate 1	mm	600.00
Gross Vehicle Weight	in intermediate fifth wheel position 1	Kg	18000.00
Gross Vehicle Weight, load on front axle(s)	in intermediate fifth wheel position 1	Kg	7038.00
Gross Vehicle Weight, load on rear axle(s)	in intermediate fifth wheel position 1	Kg	10962.00
King Pin Load	in intermediate fifth wheel position 1	Kg	9737.00
King Pin Load on Front Axle(s)	in intermediate fifth wheel position 1	Kg	1537.00
King Pin Load on RearAxle(s)	in intermediate fifth wheel position 1	Kg	8200.00
Fifth wheel position	Intermediate 2	mm	550.00
Gross Vehicle Weight	in intermediate fifth wheel position 2	Kg	18000.00
Gross Vehicle Weight, load on front axle(s)	in intermediate fifth wheel position 2	Kg	6910.00
Gross Vehicle Weight, load on rear axle(s)	in intermediate fifth wheel position 2	Kg	11090.00
King Pin Load	in intermediate fifth wheel position 2	Kg	9737.00
King Pin Load on Front Axle(s)	in intermediate fifth wheel position 2	Kg	1409.00
King Pin Load on RearAxle(s)	in intermediate fifth wheel position 2	Kg	8328.00
Sliding fifth wheel	front fork	mm	
	rear yoke	mm	

WIDTHS

Wheelbase		mm	3.800
Max exterior cab width with rear view mirrors open	(BEP W001)	mm	2534.00
Max. cab width	(BEP W002)	mm	2534
Frame width	Front (BEP W035)	mm	1080
	Rear (BEP W036)	mm	850
Width at rear wheels	Rear axle 1 (V3 / BEP W003.1)	mm	2499
Track	Front (V1 / BEP W013.1)	mm	2028
	Rear 1 (V2 / BEP W013.2)	mm	1837

OTHER

Wheelbase		mm	3.800
Approach angle	(BEP H010)	°	14
Ramp angle	(BEP H012)	°	13.90
Departure angle	(BEP H011)	°	17.00
Side member thickness	(BEP W034)	mm	7.00
Turning Radius	Overall (BEP W012)	mm	7550.00
	kerb to kerb	mm	6856.00
	interior	mm	3118.00

DTI 11 ENGINE

Max. power output: 316 kW between 1700 and 1900 rpm

Max. torque: 2050 Nm from 1000 rpm to 1400 rpm

6-cylinder in-line diesel engine - Common rail high-pressure fuel-injection (1700 bar) - 24 valves - overhead camshaft, rear-mounted timing

High pressure provided by three pumps on injector bodies

Bore 123 mm - stroke 152 mm - Capacity 10.8 L

Turbocharger

Electronically controlled fan

Direction of rotation (seen from G/B end): anti-clockwise

EEC EURO VI pollution control level

Compact post-treatment system (7th injector, catalytic converter, DPF, SCR)

Automatic regeneration of particulate filter

Soundproofing level complies with EEC standards (80dB)

ENGINE EQUIPMENT

Power mode is activated by passing the 'hard spot' at the end of the accelerator pedal stroke (kick down)

Complete gas recycling (closed circuit)

Intake air preheating cold starting device

Electronic speed limiter (90 km/h).

CLUTCH

Single-plate clutch, diameter 430 mm

GEARBOX

Optidriver gearbox AT 2412E (14.94 - 1) automated clutch. Aluminium housing. Max. torque 2400 Nm, 12 forward gears and 3 reverse gears

Choice of mode of use on steering wheel (automatic/manual)

Steering wheel mounted gear selector

Gearshifting strategy optimised for FUEL ECO

Gearbox rear intermediate housing in aluminium

RETARDER

OPTIBRAKE (power rating 300 kW at 2300 rpm), combination of the exhaust brake and valve compression braking, coupled to service brake

POWER TAKE-OFFS

Without gearbox mounted PTO

STEERING

Steering ratio 20:1 - Steering wheel diameter 460 mm

Driving on the right

AXLE

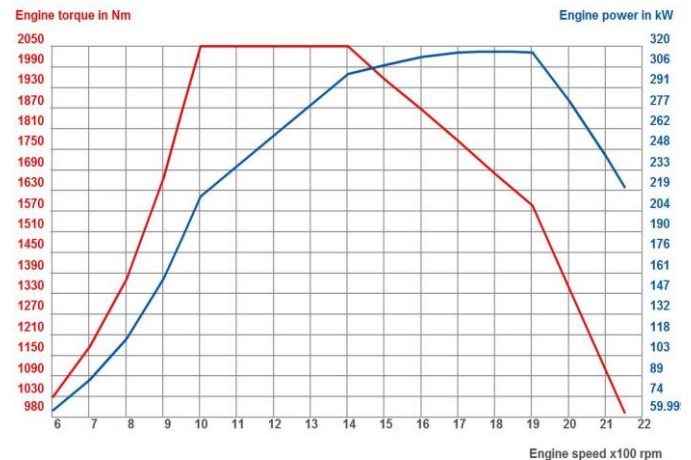

Load capacity (technical max.) Front axle: 7.5 t.

REAR DRIVE AXLE

P13170 single reduction final drive axle

Without differential lock.

Rear loading capacity (technical max.): 13 t

Drive axle ratio: 2.64

Engine speed at 90 km/h: 1280 rpm

WHEELS AND TYRES

Dimension 315/70 R 22.5

Profile B. ECOPIA H-STEER-1/H-DRIVE-1

Steel disc wheels

Front wheel trims

Spare wheel and tyre supplied loose.

BRAKING

Service brake:

Braking system with two independent circuits

Ventilated disc brakes

Electronic management of air production by EACU (Electronic Air Control Unit):

Dryer cartridge optimised by preventive maintenance.

Twin-cylinder air compressor 900 l/min, 636 cm³

Two line trailer braking system (ISO connections).

15-pin services socket

Trailer brake device at cab rear

EBS:

Anti-lock braking system (ABS).

Anti-slip regulation (ASR).

Drag torque control (Torque control during downshifting).

Brake harmonisation of tractor and trailer (if equipped)

(Disc) brake pad wear compensation

Retarder and service brake linking



Differential engagement management (if equipped) at speeds <10 km/h (4x2)
Hill Start Aid
Braking performance warning
ESC (Electronic Stability Control) trajectory control and anti-rollover system
Coupling traction test
Emergency brake assist (EBA)
Emergency brake lights (EBL)

Parking brake:

EPB (Electronic Parking Brake) automatic parking brake, immobilization provided by spring cylinders

Brake adjustment:

Automatic brake lining slack compensation.

Emergency brake:

Ensured by independence of main device circuits

CAB

Cab exterior:

All steel Cab, electro-zinc plated and cataphoretic paint treatment.
Sleeper Cab
Cab paint colour: WHITE EKLA
Full paint
Dark grey front face finish
Aerodynamic dirt deflectors on the headlamps
Four point mechanical cab suspension.
Two side doors of which one is accessible from inside the cab
2 heated, remote control rear view mirrors.
2 wide angle rearview mirrors.
Kerb view mirror.
Rear view mirrors for bodywork up to 2.55 m wide
Fold-back front view mirror
Air horn
Spray suppression on front wings
Side deflectors (left-hand opening panel)
Adjustable roof deflector.
Door extension
External sun visor.
Without rear window.

Cab interior:

Ultimate Bronze finish
Quality roof console, 2 storage compartments with doors including 1 with key lock, 3 storage spaces with nets, 4 ISO modules
Interior sun blind on windscreen and on driver and passenger side windows
MP3/WMA-compatible CD player
AM/FM tuner
radio information on the main information display
Steering wheel controls
CB pre-equipment.
Dual CAN digital tachograph
Offset 24 V socket
Electrically operated roof hatch.

Mosquito net on air vent
Rubber floor mat
Air-suspended driver's seat with fitted seat belt
Driver's armrest
Safety belt warning.
Fixed passenger's seat with seat belt.
Vinyl and fabric seat trim.
Performance lower bunk
Ultimate upper bunk, transformable into storage with ladder
Air supply to the rear of the driver's seat
Drawer under bunk with document holder
Reading lamps on overhead ledge
Direct cab lighting
Red night lighting
Cab lighting time-delay.
Curtains around cab.
Bunk restraint.
Articulated LED lamps in bunk area
Bunk area remote control
12 and 24 V sockets on bunk
Provision for 50A max. electrical power supply
24L refrigerator in central storage under bench, quiet with thermostat and vehicle battery management
2 storage boxes under bunk, one accessible from interior and exterior
2 Coat hooks on rear panel and one on passenger side
First-aid box (Germany)
Driver's window with impulse control.
Cab independent night heater air/air (4 kW)
Electronic air conditioning.
Cab air filtration
Log-book in Serbian.
2 loudspeakers.

Steering wheel equipment:

"Performance" 4-spoke steering wheel adjustable for height and depth, with control for cruise control
OPTIDRIVER control
OPTIBRAKE and retarder control on right-hand side
Easy Access steering column adjustable in 2 directions
Removable writing board on steering wheel

Instrument panel:

Panoramic dashboard
7" HD colour information display
12 V + 24 V socket on dashboard, for accessories.
Starting inhibitor controlled by transponder key.
Remote control central door locking with folding key
Soft cruise control with Optiroll



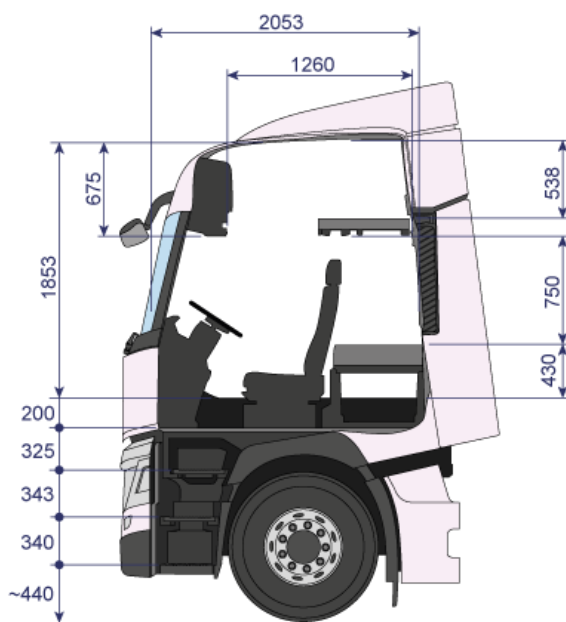
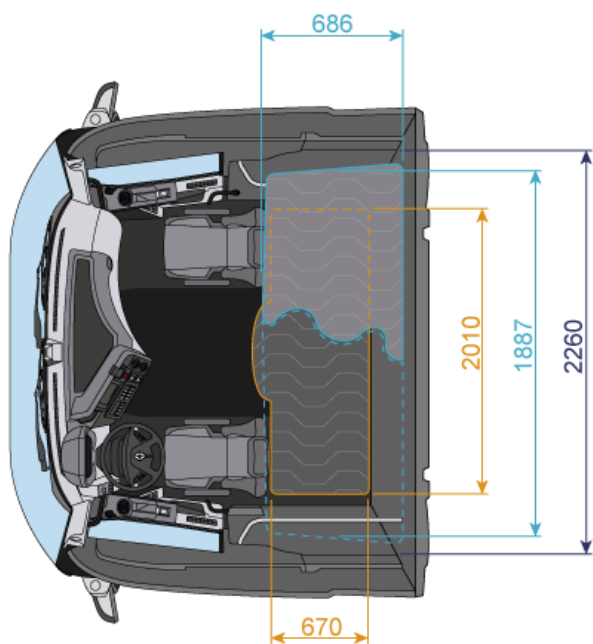

ELECTRONIC EQUIPMENT:

SAE cab socket for vehicle data extraction (Optifuel Infomax).
Toll Collect pre-equipment
Telematics provision including the TGW (Telematics GateWay): base for subscription to Optifleet Map, Check and Drive services
Lane Departure Warning System (LDWS)
Automatic emergency braking system
English and German language display
Additional language (Serbian)

ELECTRICAL EQUIPMENT

Battery capacity: 225 Ah
Batteries located in the rear overhang
Battery cut-out remote control
Electrical circuit automatically goes to standby
Alternator : 120 amp capacity.

CHASSIS

Removable front towing cap.
Front under-run protection.
Closing cross member with pre-drilling for towing yoke
Low fifth wheel mounting H=16 mm
Jost JSK 36D (sheet metal), 2" sheet metal fifth wheel, D 152 kN
Fifth wheel position: Y = 650 mm
Rear manwalk.
Rear wings with anti-spray
Lowered wing position, recommended for motorway use.
1 foldaway wheel chock
Side exhaust.

BUMPER - STEPS AND LIGHTING

3-part plastic bumper
Retractable windscreen access step in radiator grille
Access to driving position by 3 steps
Step lighting.
Electrical headlamp levelling control.
Running lights
Provision for lighting rail on front end
Coupling light (70W).
Front fog lights.
Halogen headlights
Roof beacon pre-equipment

SUSPENSION

Front suspension

2-leaf front leaf springs
Stabiliser bar

Rear suspension:

Rear air suspension.
Suspension remote control

FUEL TANK

Main and additional aluminium tanks.
Main fuel tank: 450 litres capacity D710 profile mounted on right
Main fuel tank: 900 litres capacity D710 profile mounted on left & with access steps
Fuel filter heater
Sedimenter and prefilter (R60). Bleed control on dashboard.



AdBlue

100-litre AdBlue tank
Tank on the right

STANDARD EQUIPMENT

Tool kit.
Jack 15t
Reversing warning buzzer, including night switch.
Windscreen washer bottle capacity: 12L

BODYWORK

Side marker lights.

GEARBOX RATIOS

1	2	3	4	5	6	7	8	9	10	11	12
14.94	11.73	9.04	7.09	5.54	4.35	3.44	2.70	2.08	1.63	1.27	1.00

*The manufacturer reserves the right to modify the specifications above without prior notice.
Non contractual document.*

For further assistance please contact Product Applications at Renault Trucks UK Limited, Houghton Hall Business Park, Porz Avenue, Dunstable, LU5 5FT. Telephone +44 (0)1582 471122.

Bodybuilder connection interface

SERVICE

Optifleet:

Pre-equipment for monthly Optifleet Check: technical data reports for fuel consumption monitoring by vehicle and by driver, activation of service on request subject to monthly subscription
Pre-equipment for monthly Optifleet Map: vehicle geolocation, geofencing and route analysis. Activation of service on request subject to monthly subscription

